



**BOLLFILTER**  
Protection Systems

Industry & Environment

**BOLLFILTER Automatic  
TYPE 6.03 AOT**

Unique – chemical free – sustainable!



*The 2-in-1 system  
for water filtration  
and disinfection*

# Innovative answers to today's pressing questions

Due to the growing demand for it, water has become a precious natural resource which has to be used very carefully. Furthermore, water in industrial supply circuits and especially heated or cooled water in complex distribution networks is often contaminated with potentially harmful microorganisms.

Potable Water for human consumption and miscellaneous domestic uses as well as commercial and industrial use has to be collected, treated and purified as economically as possible. The careful use of the resource water is decisive not only for the competitiveness of the economy, but also for human life and health.

The BOLLFILTER Automatic Type 6.03 AOT is used for the filtration of the following media, for example:



Cooling water



Washing water



Effluent



Irrigation water



Domestic water supply



Hotel-swimming pool

## The innovative combined solution for water treatment, two stages in one unit

A technical solution to the challenge of water treatment must not cause additional impacts on nature and the environment; it also has to be realised with as little consumption of resources as possible. The BOLLFILTER Automatic Type 6.03 AOT fulfils these requirements in a compact and efficient manner. In a very small unit, it effectively filters out particles and disinfects water at the same time.

Its virtually maintenance-free filtration stage has an automatic backflushing function with compressed air support. The disinfection stage is effected without any chemical additives (biocides) by means of photocatalysis, the AOT-method (Advanced Oxidation Technology).

The filter element **2** is positioned in the cylindrical filter housing **1**. The UV lamp **3** is installed in a quartz tube **4** positioned inside the filter element. While the fluid is passing through the filter, particles retained on the filter surface, viruses, bacteria, fungi, algae and similar microorganisms are destroyed and chemical residues (e.g. traces of medicines) are neutralised.

The BOLLFILTER Automatic Type 6.03 AOT fully replaces a conventional UV installation after a conventional filter. Instead of two units just one unit is needed to fulfil both tasks.

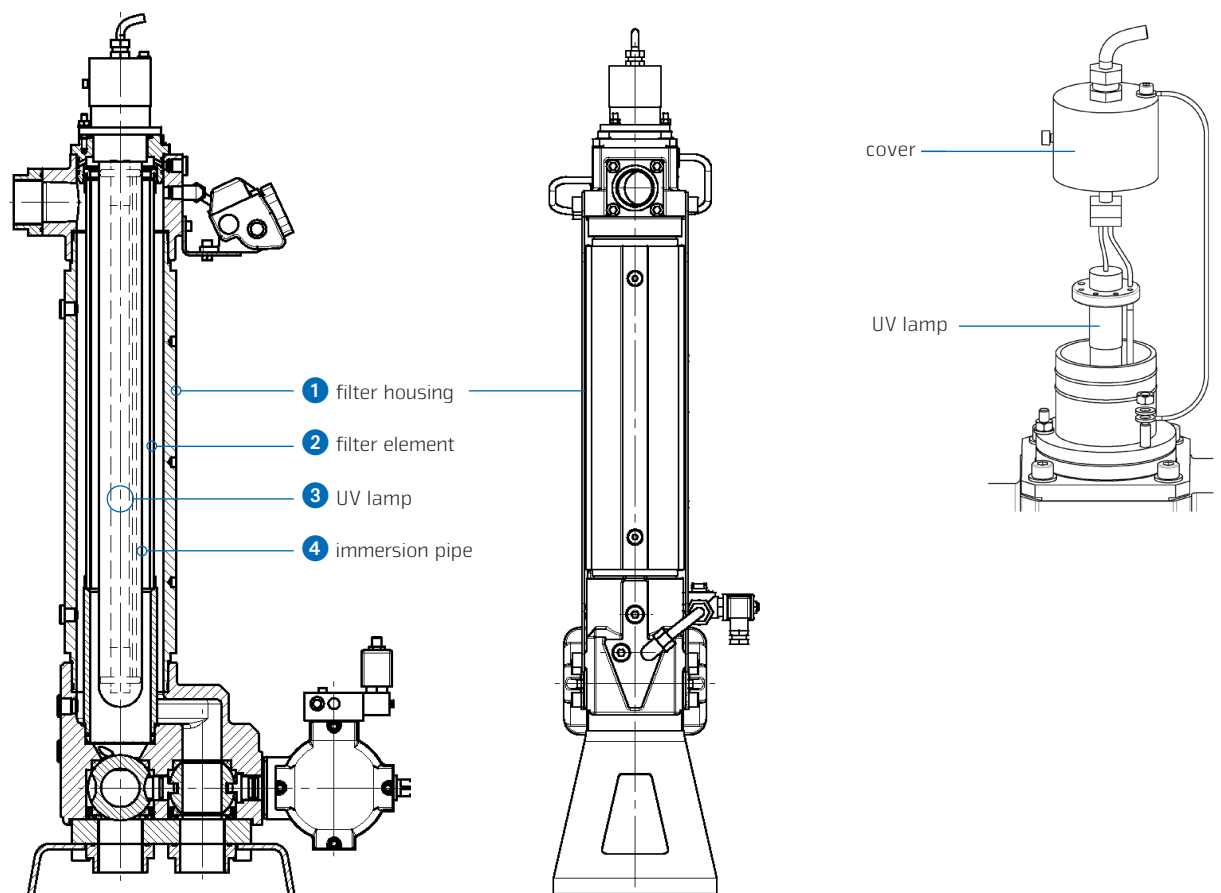

## Filtration powered by Vortex flow and pressure assisted automatic backflushing

In filtration mode the fluid to be filtered passes through the filter inlet **1** into the housing. It enters into the filter chamber **2** tangentially, causing the fluid to rotate. Centrifugal force gravitates large particles against the internal housing wall, where they sink into the lower reduced velocity area. The particles collect there until they are flushed out from the filter housing during backflushing. The fluid passes through the filtering surface of the filter element from the outside to the inside. In the process, particles in the fluid are held back on the filtering surface. The cleaned fluid flows out of the bottom of the filter element through the opened outlet valve **3** and out of the filter. The backflushing discharge valve **4** is closed.

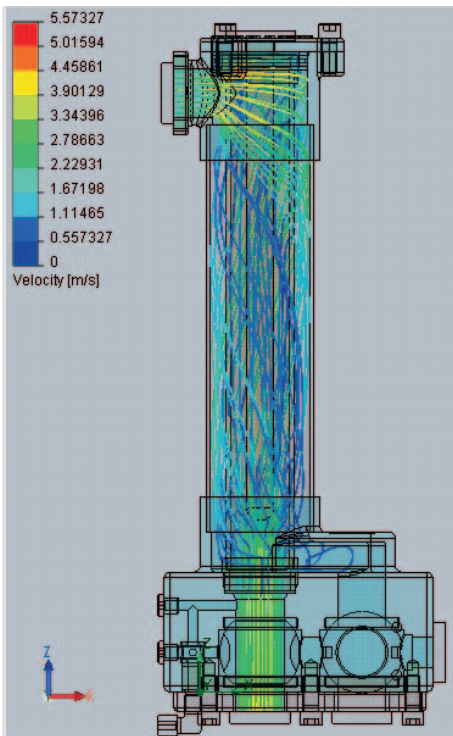

Flow pattern of the filtration process

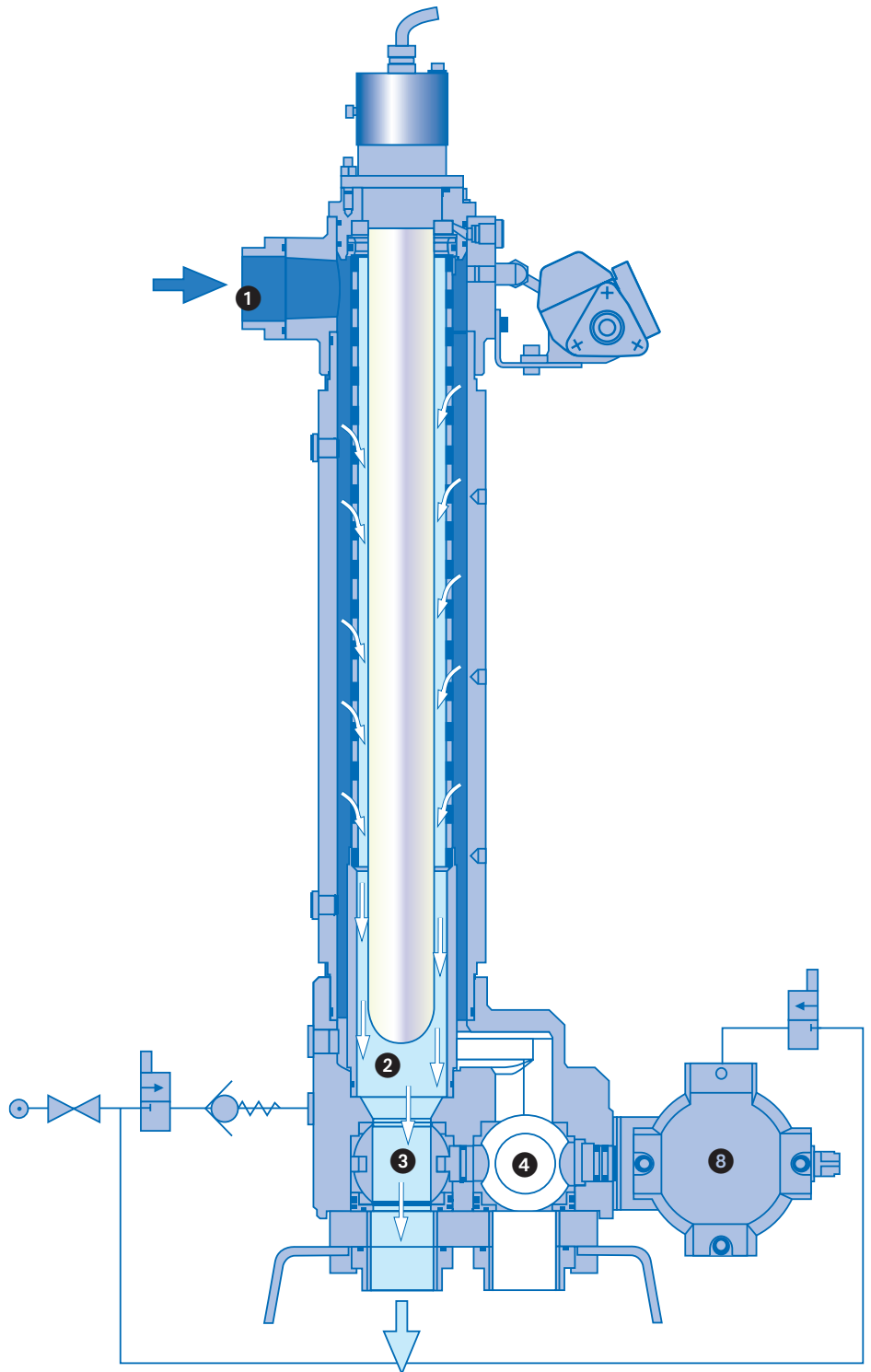

filtration

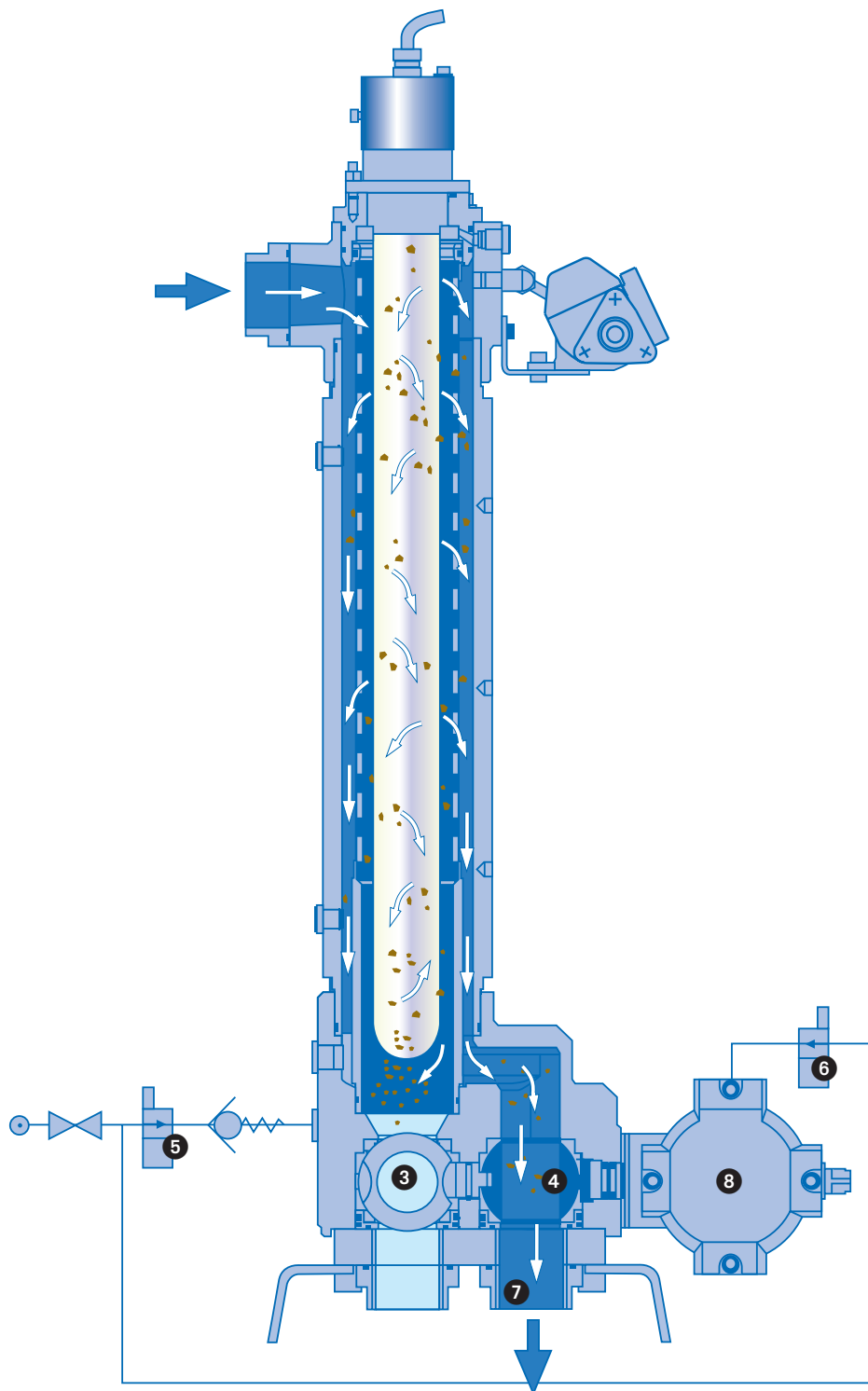

backflushing

The contaminants held back on the filter element generate a growing differential pressure between the filter inlet and outlet. Once the differential pressure reaches a certain value or a defined time has elapsed since the last backflush, the controller triggers a backflushing cycle. When backflushing is triggered, the pneumatic pivoting actuator is switched by a solenoid valve 6. This causes the outlet valve 3 to close and the backflushing discharge valve 4 to open. The particles collected in the restricted flow area are flushed out 7 of the filter chamber.

The flushing valve 5 opens after a short delay. The active compressed air is released into the filter element from below. While the air bubbles are rising, a turbulent fluid/air mixture is created. It flows through the filtering surface in reverse direction to filtration. The particles deposited on the filtering surface are flushed out through the open backflushing discharge valve together with the fluid/air mixture.

After a set time the compressed air supply is stopped by closing the flushing valve. The air which is still in the filter is flushed out through the open backflushing discharge valve. The backflushing discharge valve is then closed and the outlet valve is opened by the switch-over of the pneumatic pivoting actuator 8. The backflushing process is complete, forward flow is stopped during backflushing.

## Chemical free disinfection using UV light

The disinfection of water using UV light is performed by

- killing the contained organisms and germs using direct radiation with UV light and
- oxidation of the contained chemical compounds using photocatalysis, AOT-method (Advanced Oxidation Technology).

To make the photocatalysis procedure possible, the surface of the filter element in the BOLLFILTER Automatic Type 6.03 is coated with a catalyst. When this surface is exposed to UV light, reactive radicals are formed, which oxidise the impurities contained in the water. When a radical from a water molecule hits the cell wall of a microorganism in the water, a hydrogen atom is removed from the cell wall. Many radicals repeating this procedure destroy the microorganism. Afterwards, the radicals turn back to the water molecules and so the complete process does not leave any contaminating residuals.

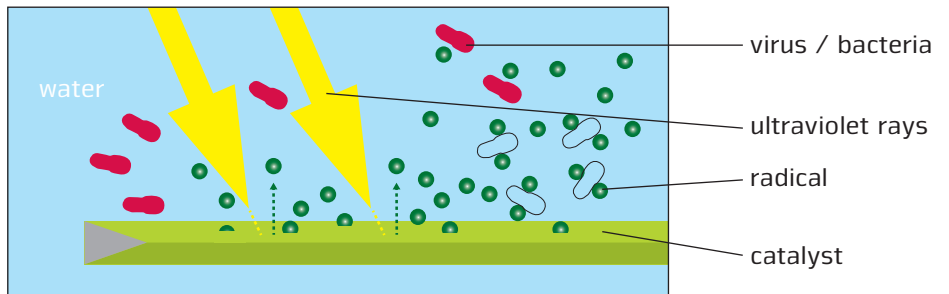
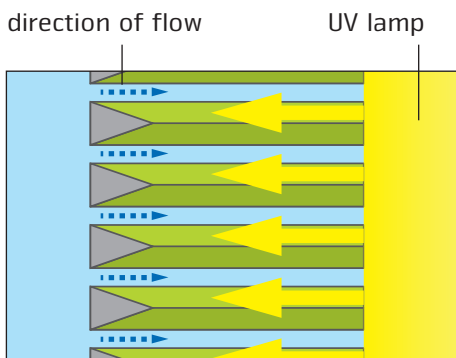

## The Details

## Data and figures at a glance

BOLLFILTER Automatic Type 6.03 AOT	
Nominal width	G 1 ½
Flow rate	15 m³/h
Grade of filtration	50 µm or 100 µm
Permissible operating overpressure	10 bar
Permissible operating temperature	max. 60°C
Operating voltage	2 ph 230 V
Frequence	50 Hz
Control voltage	230 V
Backflushing fluid	Own medium and compressed air
Control medium	clean, dry air 4-6 bar
Flushing time	3 sec.
Filter element	
Type of element filter	Wedge wire or mesh candle from CrNi-steel
Number of elements	1

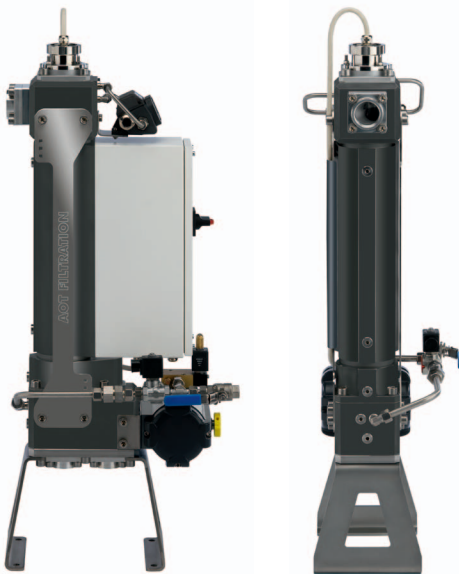

# Convincing in many respects

The unique BOLLFILTER Automatic Type 6.03 AOT offers its users many advantages with regard to economical, ecological, functional and legal aspects.

The most important advantages are:

- space savings,
- reduced maintenance,
- water treatment without chemicals (biocides),
- improved health protection for the employees, who do not have to handle chemicals,
- protection of resources and less environmental pollution,
- easy installation and integration.

# Tried and tested

This innovative 2-in-1 water treatment system, the newly developed BOLLFILTER Automatic Type 6.03 AOT, has proven its performance and reliability, for example:

- treatment of cooling water at Ericsson Power Cable Plant, where it protects the fine nozzle openings from being blocked by microorganisms,
- water treatment in a conveyor box cleaning machine at the production of BOLL & KIRCH Filterbau GmbH, where the wash water can be used much longer without quality impairments



More application examples can be found in the food industry, in agricultural watering and irrigation plants, in domestic water supply systems and in waste water purification systems.

On request, the manufacturer will introduce more reference projects to interested users.

Superior customer orientation for the highest level of satisfaction



**BOLL & KIRCH Filterbau GmbH**

P.O. Box 14 20 • 50143 Kerpen • Germany  
 Siemensstr. 10-14 • 50170 Kerpen • Germany  
 Tel: +49 2273 562-0  
 Fax: +49 2273 562-223  
 e-mail: [info@bollfilter.com](mailto:info@bollfilter.com)  
 Internet: [www.bollfilter.com](http://www.bollfilter.com)